

BOMBAS CENTRIFUGAS PARA FLUIDOS CON SOLIDOS EN SUSPENSIÓN MODELOS SA-SB-SNC

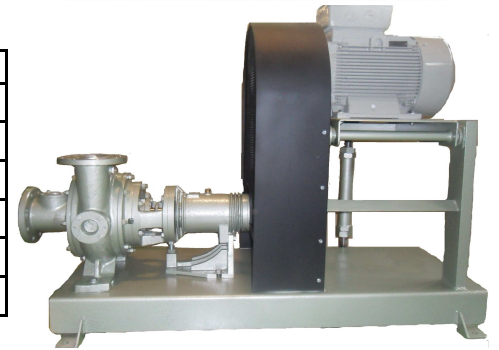

CARACTERISTICAS GENERALES
01-IMPULSOR CERRADO INATASCABLE DE DOBLE CANAL
02-PLATOS DE DESGASTE PARA DISMINUIR COSTOS GENERALES
03-CAMISA DE DESGASTE DEL EJE
04-RODAMIENTOS PARA ALTAS CARGAS RADIAXIALES
05-SISTEMA DE SELLADO MECANICO O DE EMPAQUETADURA
06-VISOR DE INSPECCION PARA FACIL LIMPIEZA DEL IMPULSOR

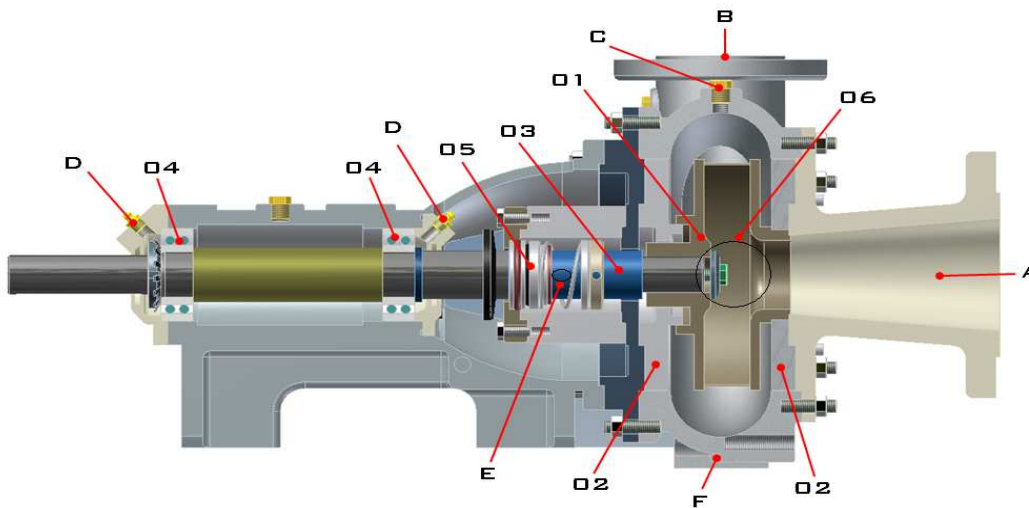

LIMITACIONES
FLUIDOS HASTA 40% DE PARTICULAS
MÁXIMA PRESIÓN SUCCION 150 P.S.I.
TEMPERATURA MÁXIMA 180°C
A-SUCCIÓN BRIDA ANSI-150
B-DESCARGA BRIDA ANSI-150
C-TAPÓN CEBADO
D-CONEXIÓN LUBRICACION
E-CONEXIÓN LAVADO DE SELLO
F-TAPÓN DRENAGE

CONSTRUCCION



PARTES PRINCIPALES	STD	INOXIDABLE
TAPA DE SUCCION	HIERRO ASTM A48	AISI-304
PLATO DE SELLAMIENTO	HIERRO ASTM A48	AISI-304
CARACOL	HIERRO ASTM A48	AISI-304
PLATOS DE DESGASTE	HIERRO ASTM A48	AISI-304
IMPULSOR	HIERRO ASTM A48	AISI-304
EJE	ACERO AISI-4140	AISI-304
CAMISA EJE	ACERO AISI-1518	AISI-420B
SELLO PRENSAESTOPA	EMPAQUETADURA AMBIENTAL	
SELLO MECANICO	21-STD	157-S-S-V

*SELLO DE PROCESO SEGÚN APLICACION

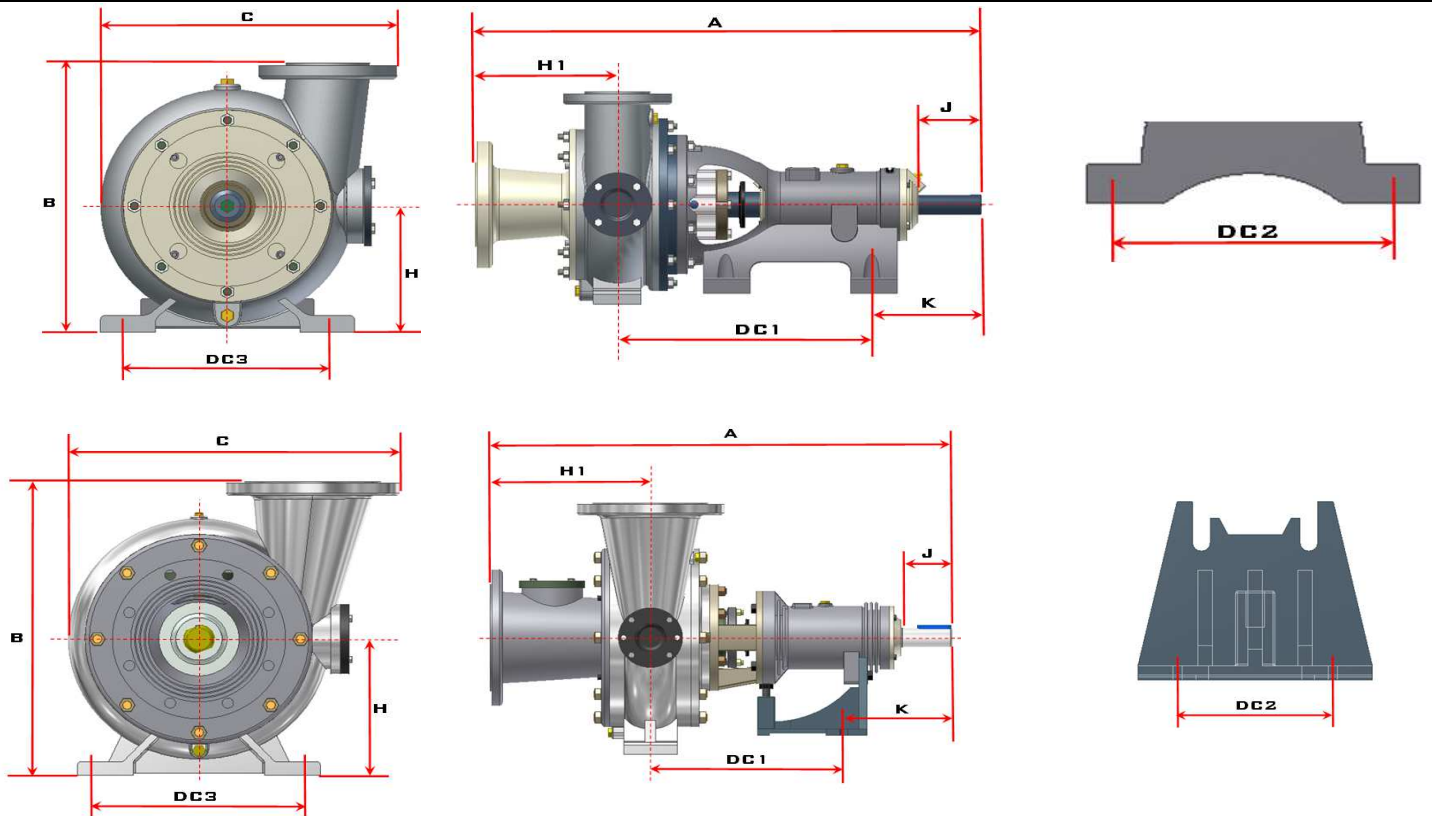

DIMENSIONES

MODELO	HP MAX	A - B	C - DC1	DC2 - DC3	H	H1 - J	K	PESO Kg
SA-1½ X 2	10	670 - 300	305 - 204	146	134	160 - 90	154	65
SA-2 X 3	15	710 - 320	320 - 204	146 - 184	150	200 - 90	154	76
SB-3 X 3	25	763 - 369	379 - 204	146 - 262	166	246 - 90	154	86
SNC-4 X 4	50	963 - 491	482 - 434	169 - 400	236	276 - 115	253	185
SNC-6 X 6	60	1030 - 544	545 - 433	169 - 450	264	343 - 115	253	241
SNC-8 X 8	100	1078 - 626	654 - 449	169 - 440	294	376 - 115	253	305

ACOPLAMIENTO

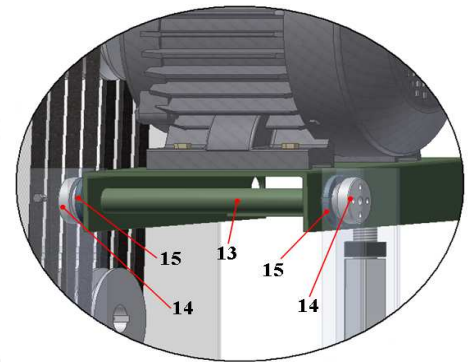
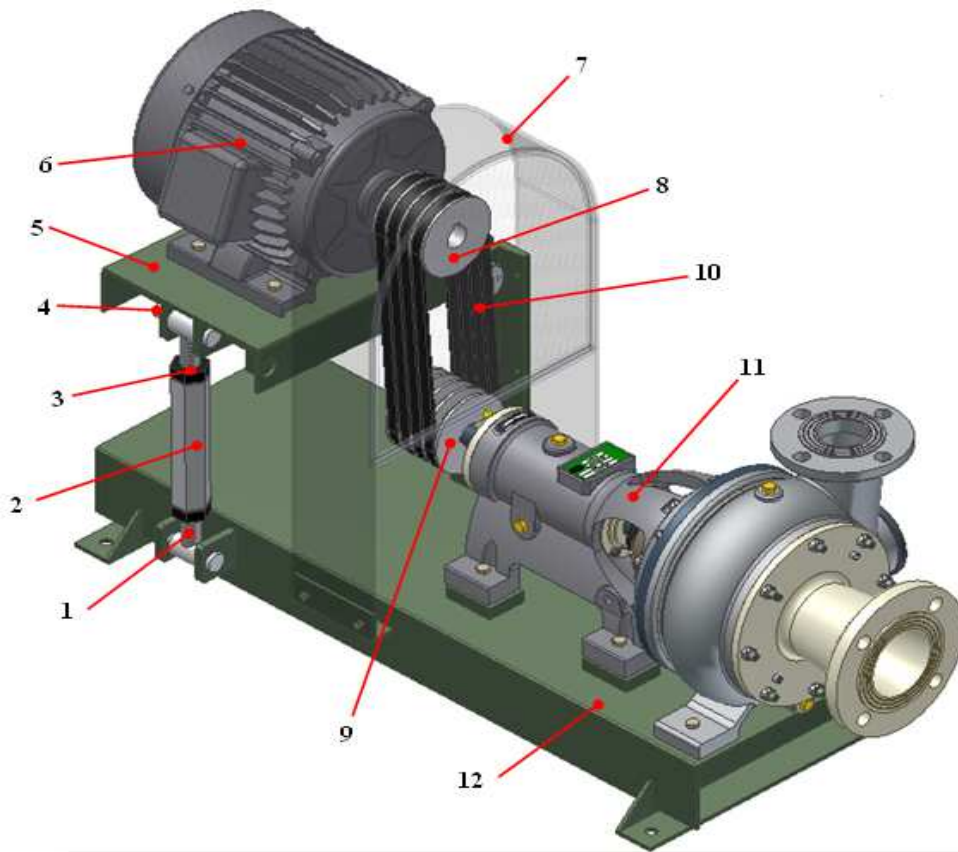

ACOPLAMIENTO TIPO MOTOR ELEVADO

- | | |
|--------------------|------------------------|
| 1-Tornillo tensor | 9-Polea bomba |
| 2-Cuerpo tensor | 10-Correas |
| 3-Tuerca de ajuste | 11-Bomba |
| 4-Pasador | 12-Base conjunto |
| 5-Base elevada | 13-Eje base elevada |
| 6-Motor | 14-Tuerca |
| 7-Guardapoleas | 15-Tuerca de seguridad |
| 8-Polea motor | |



BOMBAS HYDRAL LTDA.
www.bombashydral.com



Cra 36 No. 11A - 04
PBX: 247 5940
Fax: 247 6231 - Telefax: 247 5940
Bogotá, D.C. - Colombia S.A.

BOMBAS

VACIO
CALDERAS
PULPA - ACEITES
IND. QUIMICA
ACUEDUCTOS
MINERIA