

BOMBAS CENTRIFUGAS PARA ALTA TEMPERATURA BE-T

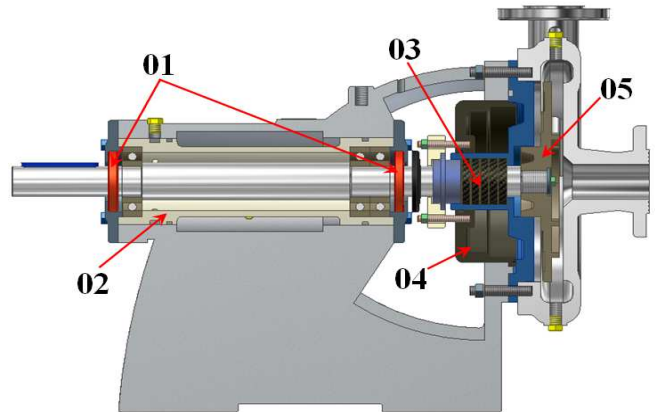

CARACTERISTICAS*
1-RETENEDOR
2-CAMISA RODAMIENTOS
3-CINTA DE GRAFITO
4-CAMISA SISTEMA SELLO
5-IMPULSOR CERRADO O SEMIABIERTO
6-SELLO MECANICO DE PROCESO

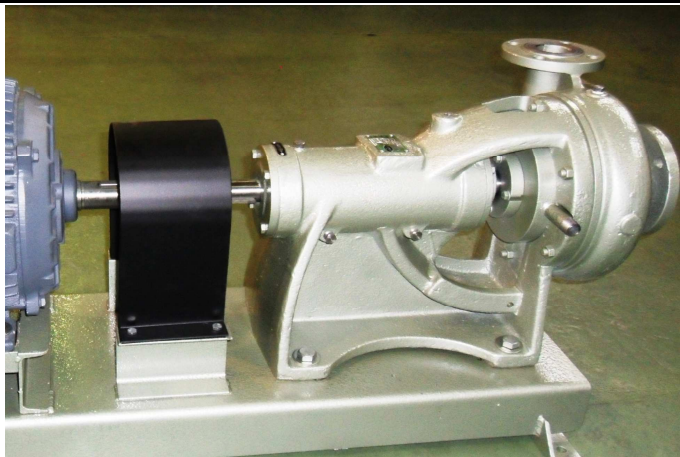
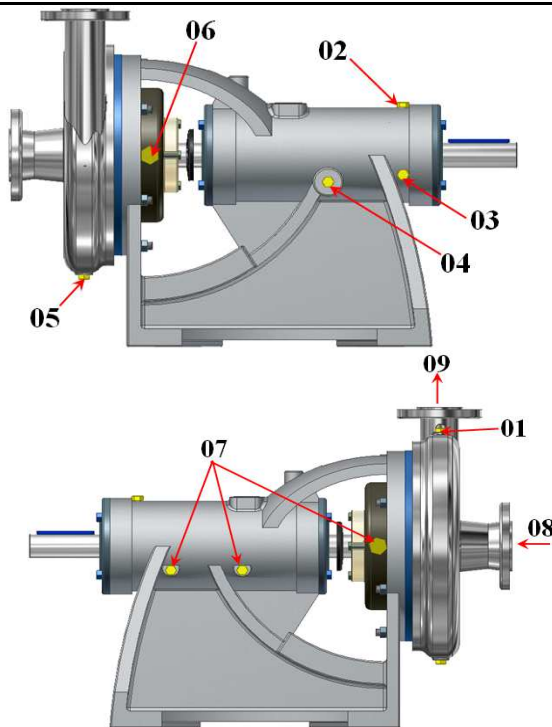
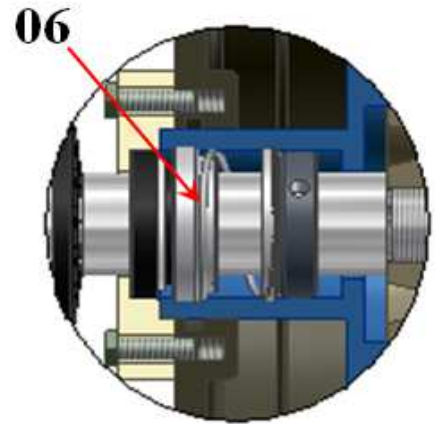

CONEXIONES
01-DESAERADO
02-LLENADO ACEITE
02-DESAERADO ACEITE
03-NIVEL DE ACEITE
04-DRENAJE ACEITE
05-DRENAJE LIQUIDO
06-AGUA REFRIGERACION
07-AGUA REFRIGERACION
08-ASPIRACION
09-DESCARGA

CONSTRUCCION



PARTES PRINCIPALES	STD	ACERO INOXIDABLE
CARCASA	HIERRO ASTM A48	AISI-304
IMPULSOR	HIERRO ASTM A48	AISI-304
PLATO DE SELLAMIENTO	HIERRO ASTM A48	AISI-304
EJE	AISI-4140	AISI-304
SOPORTE	HIERRO ASTM A48	
CHAQUETAS	ACERO AISI-1020	
SELLO PRENSAESTOPA	EMPAQUE CINTA DE GRAFITO	
SELLO MECANICO	MECANICO 157 CARAS DURAS Y AFLAS	

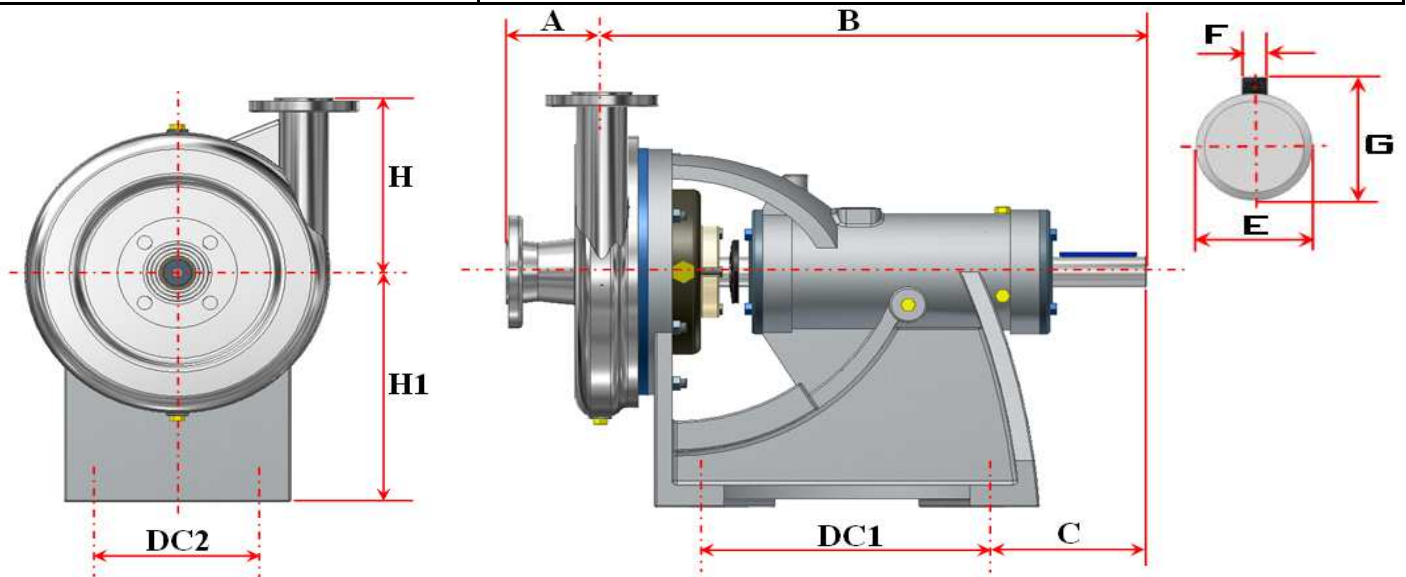

DIMENSIONES

MODELO	A - B	C - E	F - G - H	H1	Dc1	Dc2	PESO Kg
BE-8-T	100-565	160 - 1 3/8"	5/16" - 31 - 200	264	305	196	103
B-1 1/2 X 2-T	110-565	160 - 1 3/8"	5/16" - 31 - 200	264	305	196	108
BE-16-T	100-565	160 - 1 3/8"	5/16" - 31 - 200	264	305	196	110
B-3 X 4 -T	53- 575	160 - 1 3/8"	5/16" - 31 - 225	264	305	196	112



NIT. 860.007.839-4

BOMBAS HYDRAL LTDA.
www.bombashydral.com



Cra 36 No. 11A - 04
PBX: 247 5940
Fax: 247 6231 - Telefax: 247 5940
Bogotá, D.C. - Colombia S.A.

BOMBAS

VACIO
CALDERAS
PULPA - ACEITES
IND. QUIMICA
ACUEDUCTOS
MINERIA

CORTE MODELOS BT Sello Mecanico

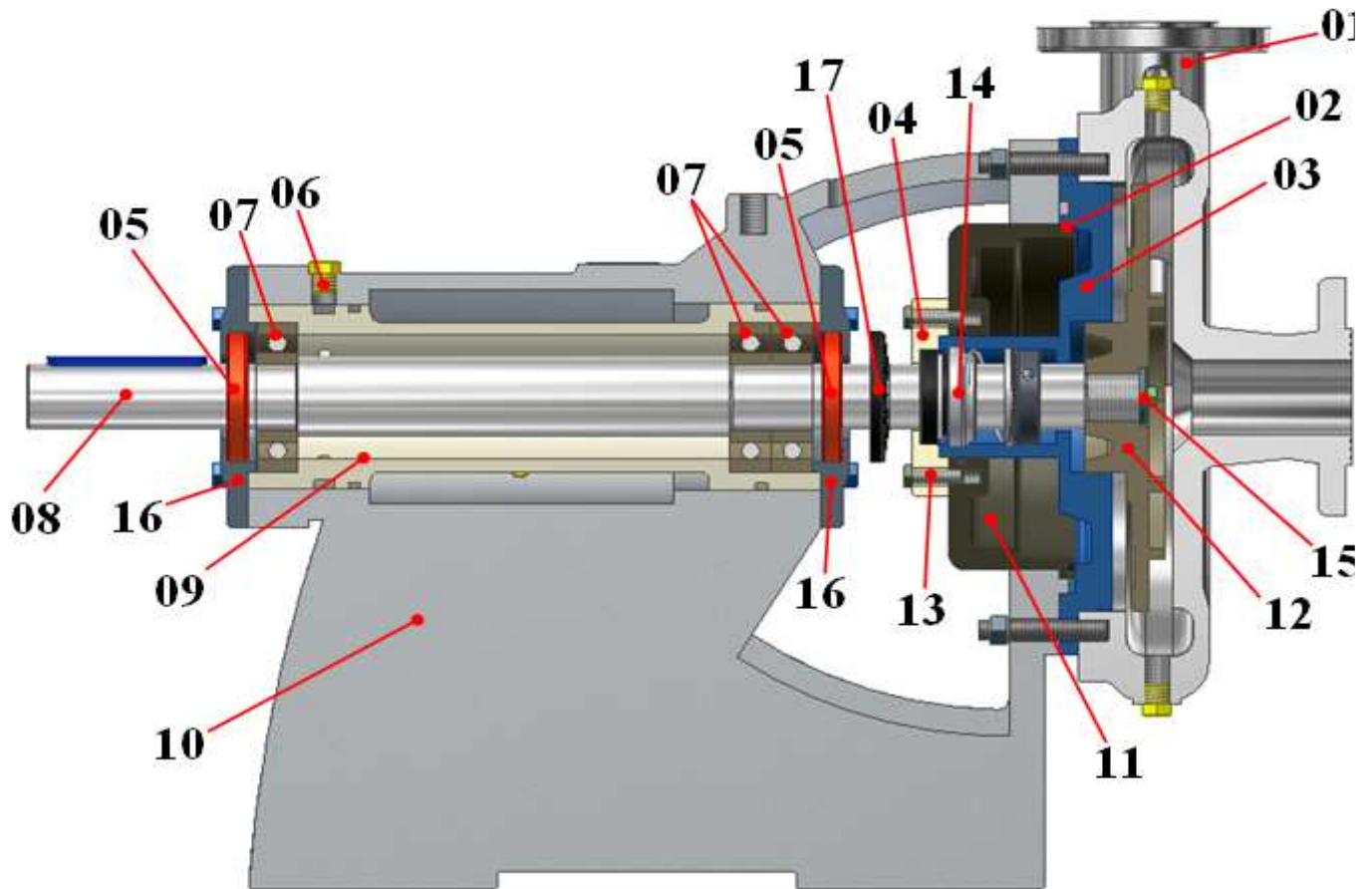

POS	DESCRIPCION	CANT	POS	DESCRIPCION	CANT
01	CARACOL	1	10	SOPORTE	1
02	EMPAQUE ANILLO "O"	1	11	CAMISA DE REFRIGERACION SELLO	1
03	PLATO DE SELLAMIENTO	1	12	IMPULSOR	1
04	BRIDA DE EMPUJE	1	13	TORNILLOS SELLO	4
05	RETENEDOR	2	14	SELLO MECANICO	1
06	TAPON LLENADO ACEITE	1	15	TORNILLO ARANDELA IMPULSOR	1
07	RODAMIENTO	3	16	TAPA RODAMIENTO	2
08	EJE CON CUÑAS	1	17	DEFLECTOR	1
09	CAMISA REFRIGERACION	1			

CORTE MODELOS BET Prensaestopa

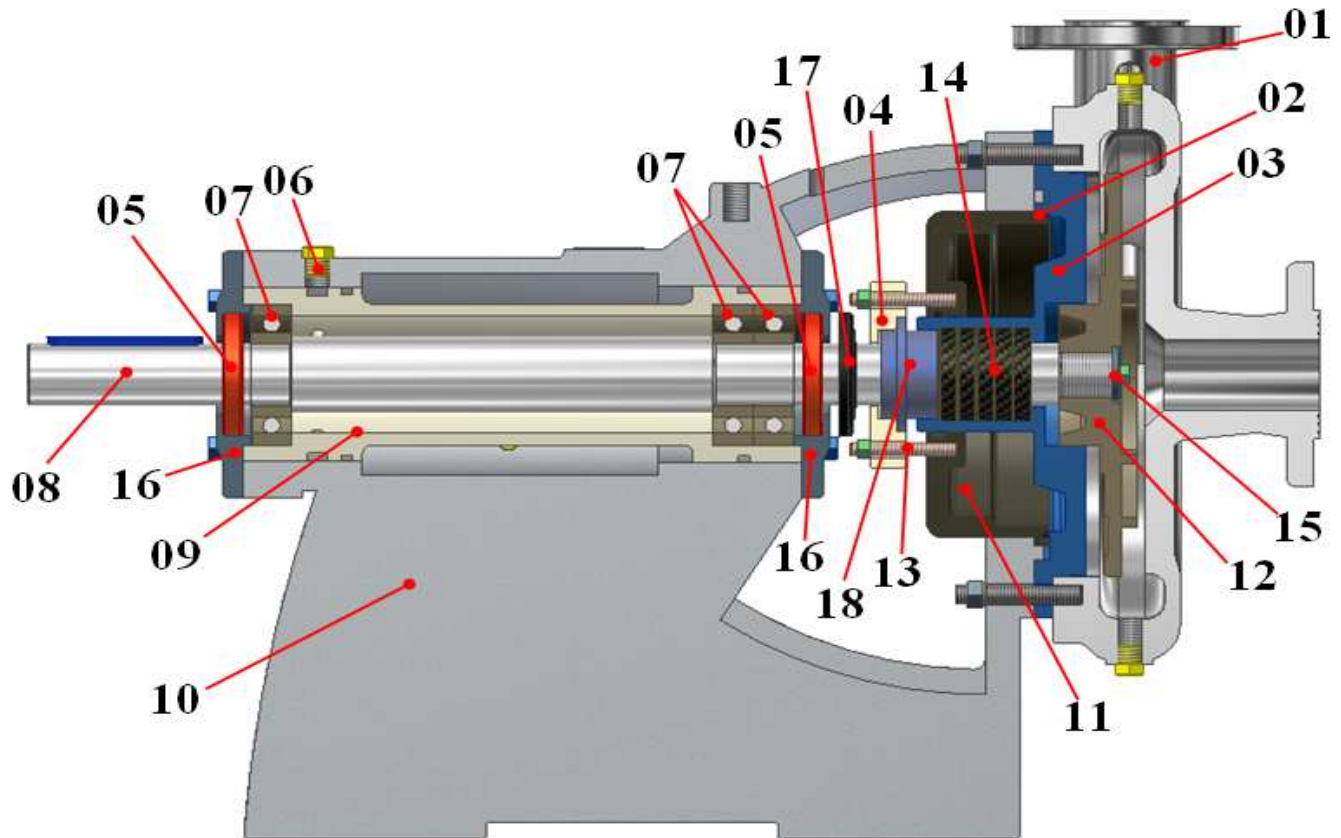

POS	DESCRIPCION	CANT	POS	DESCRIPCION	CANT
01	CARACOL	1	10	SOPORTE	1
02	EMPAQUE ANILLO "O"	1	11	CAMISA DE REFRIGERACION SELLO	1
03	PLATO DE SELLAMIENTO	1	12	IMPULSOR	1
04	BRIDA DE EMPUJE	1	13	TORNILLOS SELLO	4
05	RETENEDOR	2	14	SELLO MECANICO	1
06	TAPON LLENADO ACEITE	1	15	TORNILLO ARANDELA IMPULSOR	1
07	RODAMIENTO	3	16	TAPA RODAMIENTO	2
08	EJE CON CUÑAS	1	17	DEFLECTOR	1
09	CAMISA REFRIGERACION	1			